

The Electromagnetic Calorimeter for the $\bar{\text{P}}\text{ANDA}$ Target Spectrometer

Markus Moritz¹, K.-Th. Brinkmann¹, V. Dormenev¹, R.-W. Novotny¹, A. Ryazantsev², H.-G. Zaunick¹, on behalf of the $\bar{\text{P}}\text{ANDA}$ collaboration

¹2nd Physics Institute, Justus-Liebig-University Giessen, Heinrich-Buff-Ring 16, 35392 Giessen, Germany

²IHEP Protvino, Russia

E-mail: markus.moritz@exp2.physik.uni-giessen.de

Abstract. The future $\bar{\text{P}}\text{ANDA}$ experiment with a next generation detector will focus on hadron spectroscopy. It will use cooled anti-proton beams with a momentum between 1.5 GeV/c and 15 GeV/c interacting with various targets. This allows to directly form all states of all quantum numbers and measure their widths with an accuracy of a few tens of keV. The experiment will be located at the exceptional Facility for Anti-proton and Ion Research in Germany (FAIR), which is currently under construction. The electromagnetic target calorimeter of the $\bar{\text{P}}\text{ANDA}$ experiment has the challenging aim to detect high energy photons with excellent energy resolution over the full dynamic range from 15 GeV down to a few tens of MeV within a 2 T solenoid. The target calorimeter itself is divided into a barrel and two endcaps. The individual crystals will be read out with two precisely matched large area avalanche photo diodes. In the very inner part of the forward endcap vacuum phototetrodes will be used instead. To reach the demands of the experiment, improved PbWO₄ (PWO) scintillator crystals, cooled down to -25°C have been chosen. They provide a fast decay time for highest count rates, short radiation length for compactness, improved light yield for lowest thresholds and excellent radiation hardness [1]. The main part of the 15,740 crystals needed have been produced by the Bogoroditsk Plant of Technochemical Products (BTCP) in Russia. After stopping their business, a new potential producer for the missing 41% of crystals have been found. The company Crytur in Czech Republic provided 150 promising preproduction crystals so far. Except some of the very first produced crystals, all samples exceed the required high quality parameters. Most of them have already been used for the first major assembly stage of assembling one of the 16 barrel slice segments, which will be presented as well.

1. Introduction

The unique FAIR facility near Darmstadt (Germany) is currently under construction. It will operate various physics programs in parallel. For this purpose, proton beams with momenta up to 30 GeV/c or heavy ions with momenta up to 35 GeV/c can be distributed through a complex accelerator facility composed of many different branches for experiments like APPA, CBM and NUSTAR. Cooled Antiprotons up to 15 GeV/c will be available as a secondary beam at the High Energy Storage Ring (HESR). For a better understanding of quantum chromodynamics, which is the state of the art for the description of strong interactions, the $\bar{\text{P}}\text{ANDA}$ experiment will search for undiscovered charm-meson states and glueballs produced via antiproton-proton annihilations.

It is designed as a fixed target experiment with highest luminosities up to $10^{32} \text{ cm}^{-2}\text{s}^{-1}$. The whole detector will be divided into a target spectrometer and a forward spectrometer. Both parts will include typical components for such experiments, like tracking, particle identification and calorimeters within strong magnetic fields. A detailed schematic can be found in the Fig. 1. The $\bar{\text{P}}\text{ANDA}$ calorimeters have to cover almost 4π for an efficient reconstruction of very complex final states. Due to the 2 T superconducting magnet of the target spectrometer a very compact calorimeter is needed. The expected annual dose will be in the order of 125 Gy in the most forward part, which demands everything to be radiation hard. An effective background rejection, especially for the very complex final state channels, is mandatory. Therefore, the calorimeter has to provide an excellent energy resolution over a huge dynamic range from 10 MeV up to 15 GeV. All those specifications lead to the decision to chose PWO-II as scintillator material. It provides a small radiation length (0.89 cm), a short decay time of 6.5 ns for the major component (97 % of the total light output) and an improved average light yield of 20 phe/MeV, compared to PWO-I with 10 phe/MeV in average, measured at room temperature using a phototube with bialkali photocathode. To increase the light output further by a factor of 4, the calorimeter will be operated at -25°C .

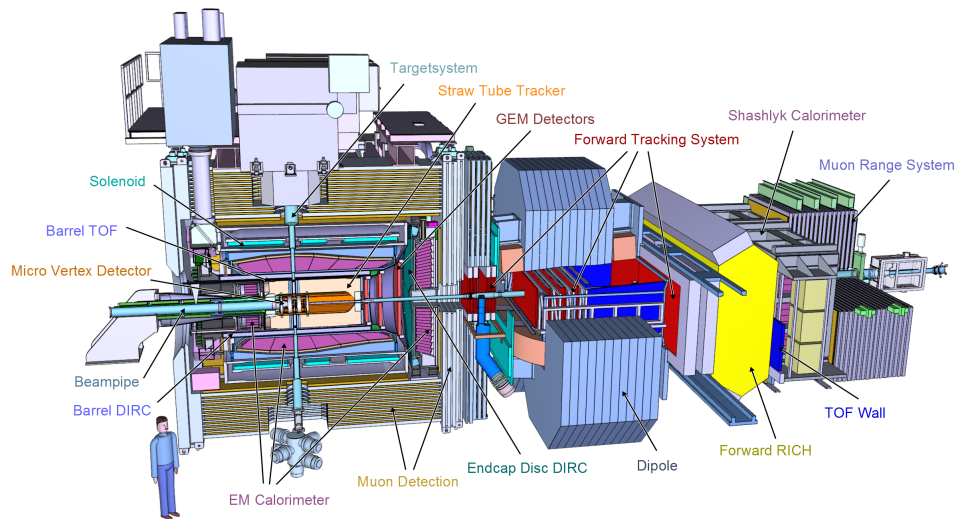

Figure 1. Drawing of the $\bar{\text{P}}\text{ANDA}$ detector. The electromagnetic calorimeters are drawn in purple.

2. The quality of PWO-II Crystals produced at Crytur

The main Part of the 15,740 crystals needed in highest quality have been produced at the Bogoroditsk Plant of Technochemical Products in Russia right after the approval of the Technical Design Report. By now, this company do not exist anymore. Due to the still small but growing market for such scintillators only one company has been found which was able to deliver the necessary high quality and quantity for the missing crystals, Crytur in the Czech Republik. Within a remarkable short research and development phase in collaboration with the $\bar{\text{P}}\text{ANDA}$ collaboration 150 preproduction PWO-II crystals have been produced already in $\bar{\text{P}}\text{ANDA}$ geometry. All these crystals have been tested at the quality control facilities in Giessen in order to compare the results to the required specifications.

2.1. Optical performance

The optical transmission has been measured longitudinally. Figure 2 shows the measured transmission values at the relevant wavelengths of 360 nm, 420 nm, and 620 nm. All values are well above the specification limits of 35 %, 60 % or 70 %, respectively. None of the crystals had to be rejected due to insufficient transparency. No indications of absorption bands have been found in the transmission curves (Fig. 3).

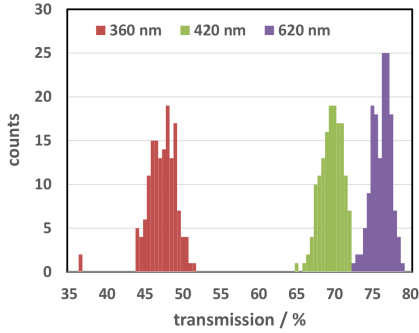

Figure 2. The distribution of the longitudinal optical transmission at three different wavelengths of all of the 150 preproduction PWO-II crystals in PANDA geometry.

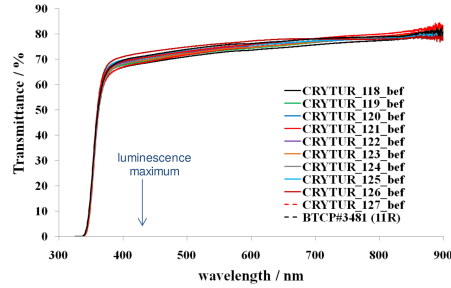

Figure 3. Exemplary full transmission spectra of the longitudinal measurement of a few samples. No absorption bands have been observed in the preproduction crystals.

2.2. Light yield

The light yield was measured with exactly the same setup and procedure used for the quality control of the previous crystals from BTCP. It was performed inside a climate chamber at 18°C with a standard photomultiplier with fused silica window and bialkali photocathode (Hamamatsu R2059, QE(420 nm)=23%). The signal caused by 662 keV γ -rays of a ^{137}Cs -source have been calibrated with the single photo-electron peak. All preproduction crystals pass the requested specification limit of more than 16 phe/MeV, except one (Fig. 4). More than 90% of the light can be collected within the first 100 ns (Fig. 5).

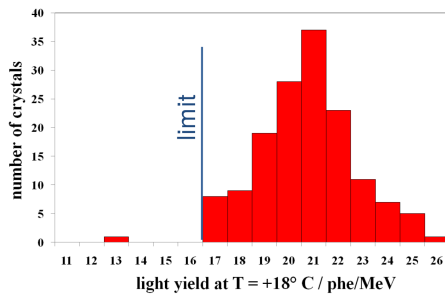

Figure 4. The distribution of the light yield of the 150 preproduction PWO-II crystals measured at T=18°C.

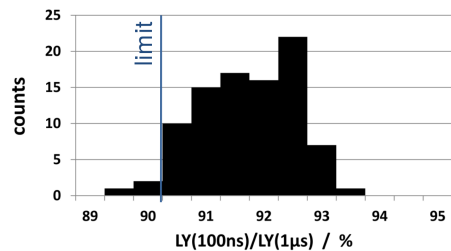

Figure 5. The ratio of light yield for different integration times at T=18°C. In nearly all crystals more than 90% of the light output can be collected within the first 100 ns.

2.3. Radiation hardness

One of the most important parameters is the radiation hardness of the crystals. There is a dose dependent change of the absorption coefficient k , in the transmission $T(x) = T_0 \cdot e^{-k \cdot x}$, which will have a direct negative impact on the energy resolution. For quantifying this parameter a set of ^{60}Co sources at the irradiation facility in Giessen was used to irradiate the crystals with an integral dose of 30 Gy within 26 minutes. After a defined rest of 30 minutes, to exclude fast spontaneous recovery processes, the longitudinal transmission measurement was started and the values compared to the measurement before irradiation (Fig. 6). For $\bar{\text{P}}\text{ANDA}$ a $\Delta k \leq 1.1 \text{ m}^{-1}$ at 420 nm ensures that light losses due to radiation damage accumulation are tolerable for a period of 6 months of operation even at -25°C and without application of the foreseen stimulated recovery (patent TM 382 DE). Some of the very first produced preproduction crystals from Crytur in the research and development phase did not reach the radiation hardness specification. After adjustments to the production process, all following crystals passed the limit so far.

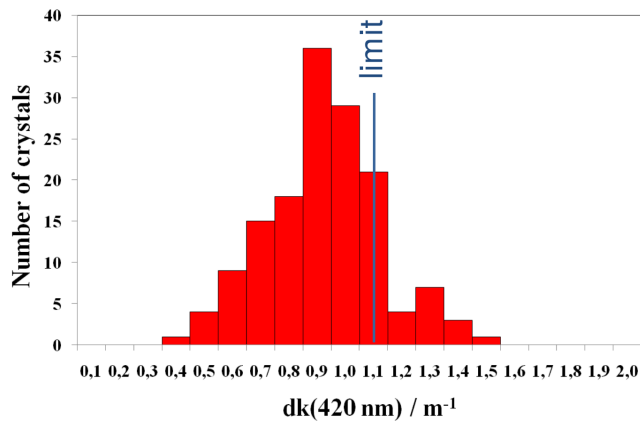

Figure 6. Distribution of the radiation induced absorption coefficient Δk measured at room temperature for the 150 Crytur preproduction crystals for a dose of 30 Gy. The rejected crystals with a $\Delta k > 1.1 \text{ m}^{-1}$ were among the very first produced samples.

3. Prototype measurements

In order to optimize the mechanical design, to fulfill space requirements, to study insulation and detector cooling and to reach an optimum overall performance in particular with respect to the energy resolution, two prototypes (PROTO60 and PROTO120) have been constructed earlier containing 60 and 120 crystal units, respectively. Important results and experiences gained with these prototype detectors went into the construction of the full size barrel slice and were used to develop and optimize the envisaged assembly procedure. Especially the energy resolution (Fig. 7), timing and position reconstruction were systematically studied and optimized utilizing the two prototype systems [2-5]. Both prototypes exceeded the envisaged goals. The expected performance of the final detector is considered to be in close accordance to those measurements since the full scale EMC is comprised of a modular combination of prototype-sized units.

4. The Barrel assembly of the $\bar{\text{P}}\text{ANDA}$ Calorimeter

The inner radius of the the barrel amounts to 570 mm and the outer to 940 mm. It covers a polar angular region between 22° and 140° . Each crystal has a 4° tilt downstream to minimize the particle interaction with the non sensitive material between each detector. The full barrel consists of 11360 PWO-II crystals in 22 different geometries of tapered parallelepiped shapes. The barrel is subdivided into 16 slices, 710 crystals each. A schematic overview is shown in Fig. 8. The volume of each slice is divided into a dry nitrogen flushed cold volume within a thermal insulation and a warm volume. The mechanical structure inside the cold volume is composed of seven different super-modules (Fig. 9) and each super-module of modules. The

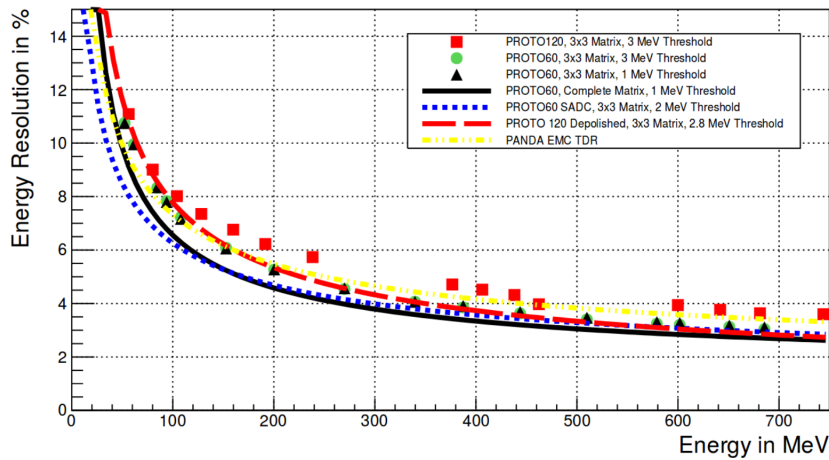

Figure 7. Comparison of the energy resolution of the two different prototypes [5]. The PROTO60 used conventional low noise transistor circuits as preamplifiers. In the PROTO120 they have been replaced by low power ASICs with shorter shaping time.

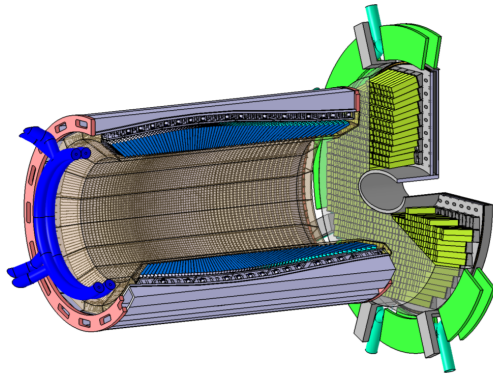

Figure 8. The barrel and the Forward Endcap of the \bar{P} ANDA target calorimeter. The barrel is subdivided into 16 slices.

modules itself are consisting of carbon fiber alveoli (Fig. 10), which accommodate the single crystal units. Each crystal is wrapped in reflector foil consisting of the 3M radiant mirror film DF2000MA and read out from the backside via two glued large area avalanche photo-diodes (APD) followed by a low noise and low power ASIC preamplifier (APFEL) [6]. In addition, several thin temperature sensors will be mounted onto the surfaces of selected crystals for online temperature monitoring. Each super-module is linked via glass-fiber support feeds to a support beam across the thermal insulation. The support beam itself contains stacked backplanes for the slow control, high voltage distribution and adjustment for each APD, buffers and line drivers. Finally the support beams of the fully assembled 16 slices will be fixed on two support rings (Fig. 11), which rest on the inner vessel of the cryostat.

4.1. Crystal Units preparation

For an improved light collection the two APDS are optically coupled to the backside of each crystal. In order to guarantee an excellent and reliable long term performance, a special transparent and radiation hard glue is used [7]. The gluing procedure itself is performed under clean room conditions to avoid any light loss due to impurities. Special gluing stations have been designed to provide well defined APD positions and contact pressure during the cure (Fig. 12). After at least 2 hours of hardening, the bonding can be inspected through a window in front of the stations. In a next step, the crystals were wrapped in laser cut DF2000MA reflective foil to improve the light collection.

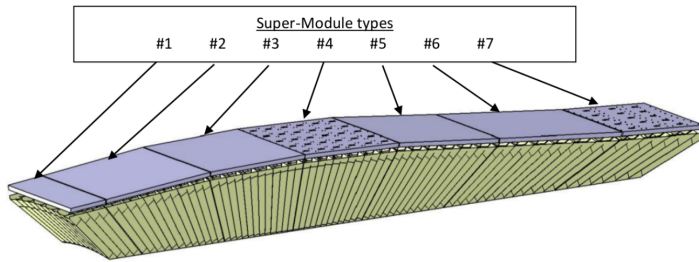

Figure 9. Modular structure of a slice of the barrel calorimeter. Seven super-modules add up to one slice.

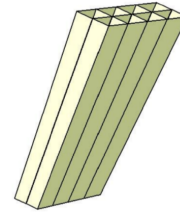

Figure 10. Carbon fiber alveoli which hold the wrapped crystals in reflector foil.

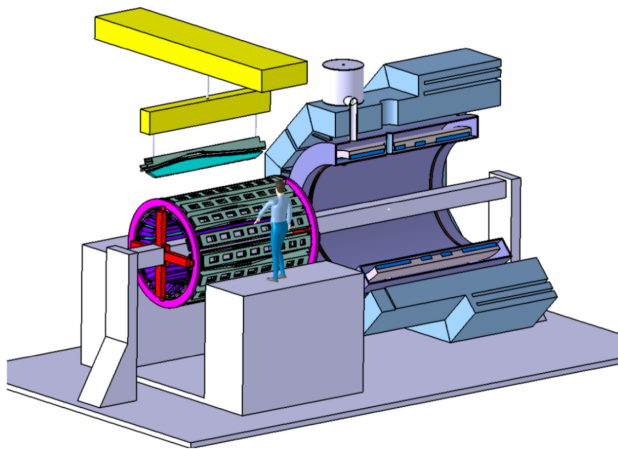

Figure 11. Assembly of the full barrel. Each support beam of the 16 slices will be connected to support rings.

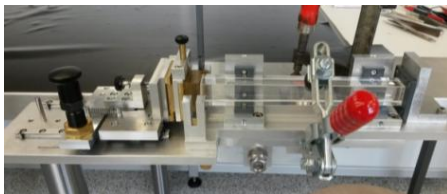

Figure 12. Picture of one gluing station. A spring loaded screw on the left side provides constant pressure during the cure in a clean room environment.



Figure 13. Finished single crystal-unit with reflector and capsule on top of the APDs. After this step each unit will be inserted into the carbon fiber alveoli.

4.2. Assembly of Modules, Supermodules and the first Slice

The crystal units are inserted into the alveoli, which are sitting in special mounting tools. In total, 18 differently shaped alveoli with their individual mounting tools are necessary to compound a slice. After the insertion aluminum inserts are glued on the alveoli at the backside of each crystal unit, which provide the mechanical connection to the support structure and a fixation for the housing of the APFEL preamplifier. The housing is a sophisticated enclosure which provides shielding against external electromagnetic fields, heat transfer and an additional opening for a radiation damage annealing LED, which can be found on the PCB of the APFEL.

A package of an insert, ASIC with its enclosure and the APD capsule can be seen in Fig. 14. Depending on the individual shape of each module several individual support tools are needed for assembling one super-module (Fig. 15). In a next step those super-modules are combined within a slice mounting tool, which can be seen in Fig. 16.

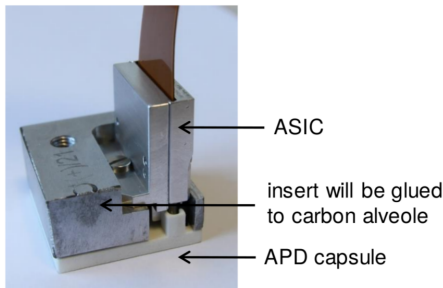

Figure 14. A package of insert, APFEL ASIC inside the enclosure and APD capsule. Such packages are located behind each crystal unit.

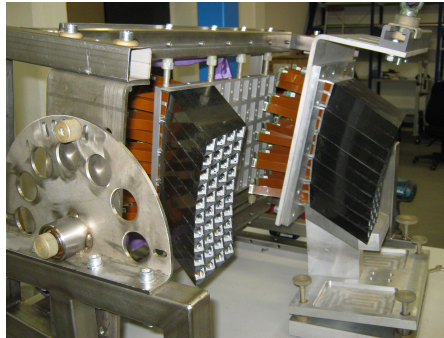

Figure 15. Assembly of a super-module by combining several modules to a super-module-plate. For each module shape individual table handling devices are necessary. One of them can be seen at the right side.

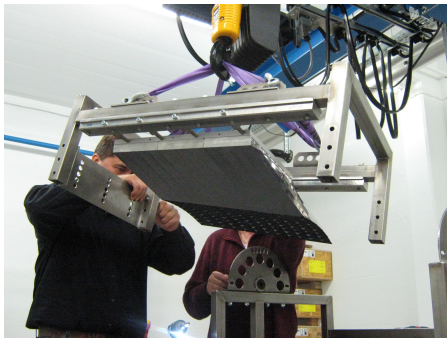

Figure 16. Assembly of the first slice of the \bar{P} ANDA barrel calorimeter including the support-beam (right picture).

4.3. Backplanes

The present design consists of a package of 3 layers of PCBs. Each package is connected to four crystal units. The top PCB is used for the distribution and individual regulation and measurement of the high voltage for the APDs. It allows to lower the input voltages in 0,1 V steps. Furthermore, each current through the APDs can be monitored. A four channel prototype is shown in Fig. 17. The second board is a connector board for the ultra thin signal cables, which have been especially developed for the barrel slice. The lowest board connects with flexible PCBs to the APFEL ASICs, it provides differential line drivers, buffers for the APFEL, temperature and humidity sensors.

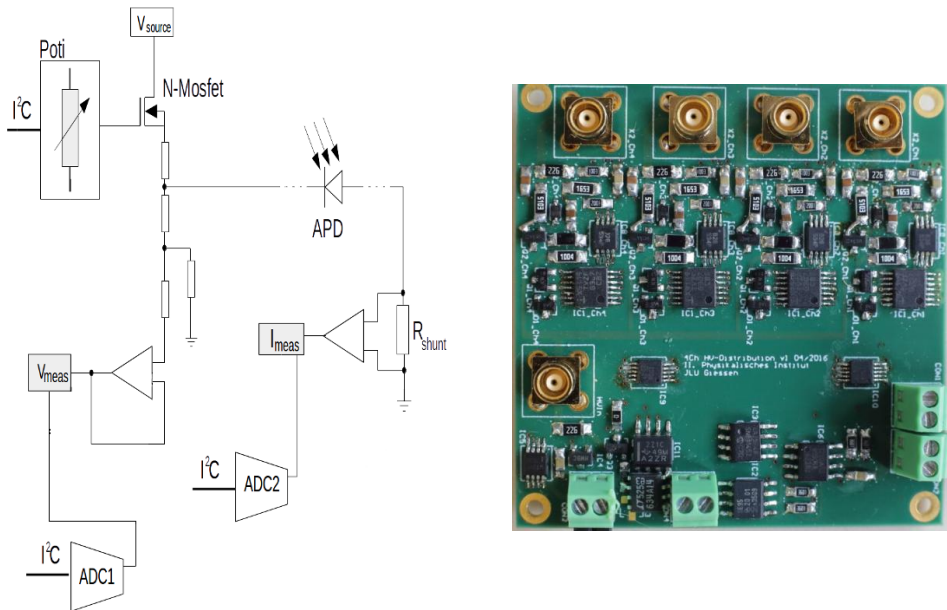

Figure 17. Four channel prototype of the APD HV regulation board.

5. Conclusion

59% of the crystals for the calorimeter of the PANDA target spectrometer are already available. In order to assemble full slices, certain crystal shapes have yet to be produced. For the missing ones, Crytur provided 150 promising preproduction crystals. After a short research and development phase, they were able to deliver PWO-II crystals with a very high and reliable quality. Those crystals are already used to complete the first slice. The mass production of the missing crystals for the second slice start in 2018.

After a successful assembly of the first slice, the mass production of the mechanics start in 2018 as well.

6. Acknowledgments

This work was supported in part by the German Ministry of Education and Research (BMBF) and the Helmholtz International Center for FAIR (HIC for FAIR).

References

- [1] The PANDA Collaboration, PANDA EMC Technical Design Report, arXiv:0810.1216v1.
- [2] M. Moritz, Measurements and improvements of the response of the PANDA-EMC prototype PROTO 60 to high energetic particles and photons in accelerator experiments, <http://geb.uni-giessen.de/geb/volltexte/2013/10105>.
- [3] T. Eissner, The new PWO Crystal Generation and Concepts for the Performance Optimisation of the PANDA EMC, <http://geb.uni-giessen.de/geb/volltexte/2013/10382>.
- [4] D. Bremer, Measurements and simulations on position dependencies in the response of single PWO crystals and a prototype for the PANDA EMC, <http://geb.uni-giessen.de/geb/volltexte/2014/10582>.
- [5] C. Rosenbaum, Optimization of the Front-End electronics of the PANDA barrel EMC, <http://geb.uni-giessen.de/geb/volltexte/2016/12281>.
- [6] H. Flemming and P. Wieczorek, Low noise preamplifier ASIC for the PANDA experiment, 2011 JINST 6 C12055.
- [7] A. Dbeyssi et al., Tests of optical glues for the PANDA electromagnetic calorimeter, Nucl.Instrum.Meth. A722 (2013) 82-86.